

SM-Series External-Mount End Block

The SM is our largest external-mount end block.

External end blocks have a wider substrate coverage than internal models.

To match any system, drive shaft length is customizable, and drive motors can be mounted inward or outward and at any angle around the main housing.

Magnet bar adjustments—to any angle—are made externally. All utilities are external and remain attached during target changes. The water seal cartridge is easily accessed for quick replacement.

Use in new systems or upgrade from planar systems.

SCI can provide coater integration support.



Patented SM end block

TECHNICAL SPECIFICATIONS

Maximum Power	▶ 200 kW DC or MFAC
V/A	▶ 1500 V 450 A
Maximum Target Length	▶ 4000 mm
Maintenance	▶ 1 hr./yr. average 3 hrs. for a rebuild



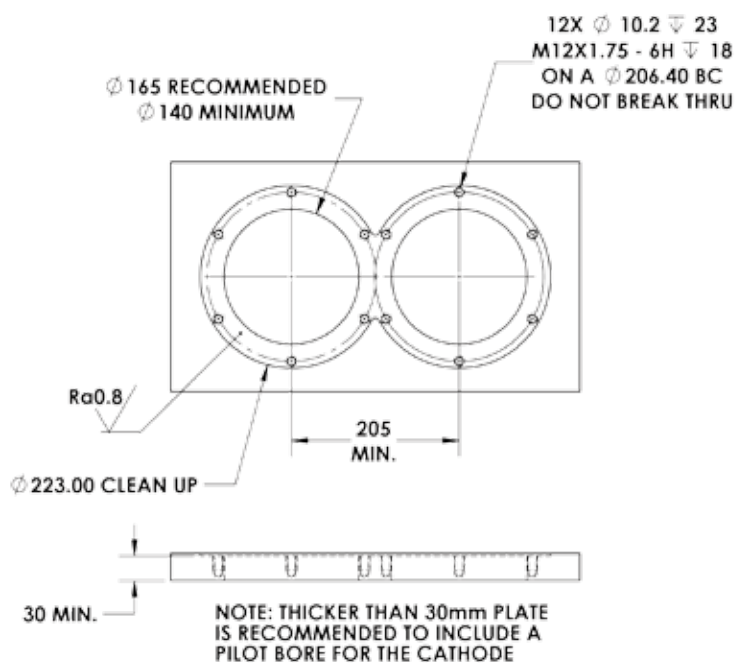
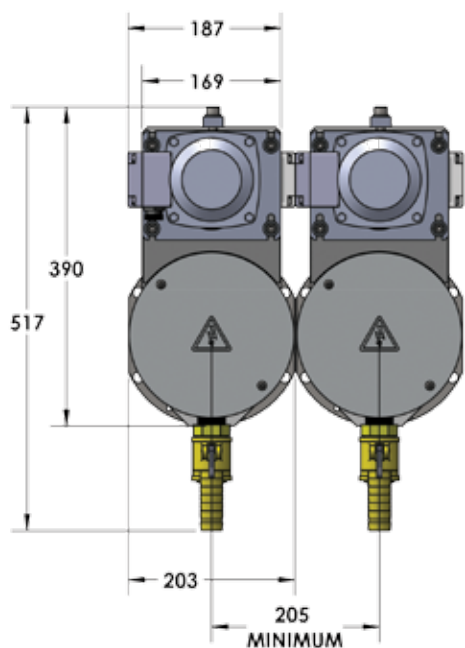
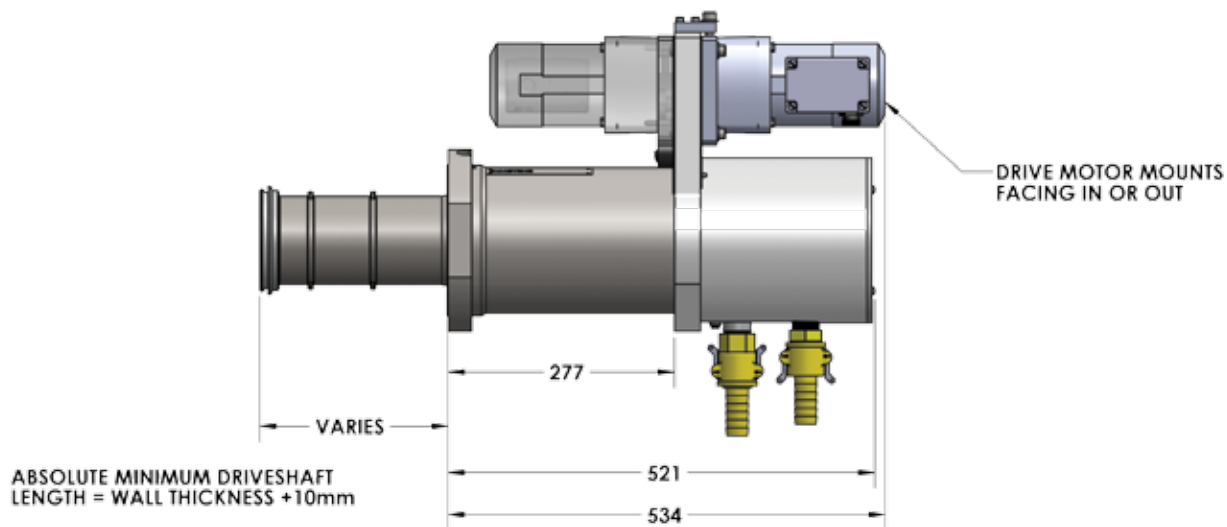

Cantilever capability

Metric: $XY/2 + 16X^2 \leq 92$

Imperial: $XY/2 + 0.9X^2 \leq 8000$

X = Backing tube length (meters or inches)

Y = Weight of target (kg or lb only)

Notes: The formula assumes a stainless steel backing tube; other materials may not qualify.

The formula must be adjusted for long drive shafts or if a RAM-Bar™ will be used.

Dimensions in mm